

Environmentally Friendly & People-Safe Carry-Deck Cranes

✓ Battery Power Mode for Zero Emissions & Quiet Operation

✓ Charging Engine Mode for Continuous Operation (Hybrid Option)

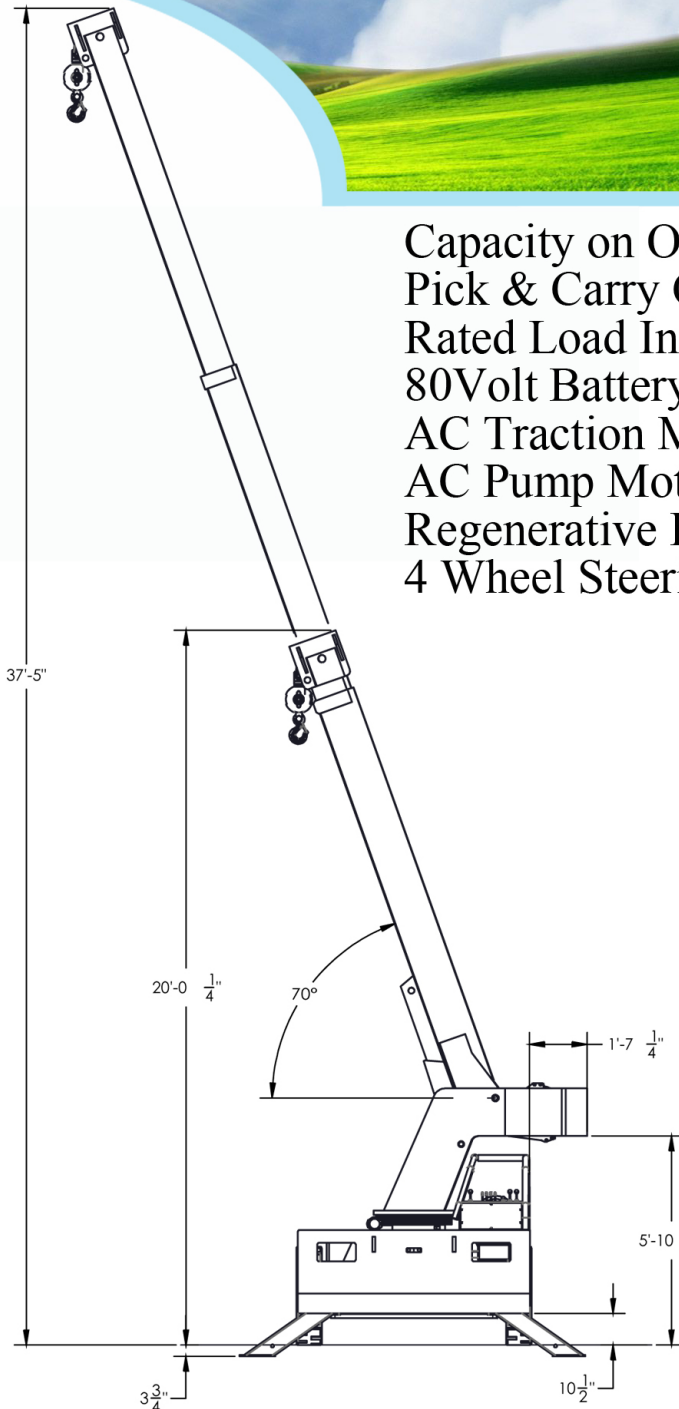

Capacity on Outriggers18,000 lbs
 Pick & Carry Capacity11,700 lbs
 Rated Load Indicator
 80Volt Battery Power
 AC Traction Motors
 AC Pump Motor
 Regenerative Braking
 4 Wheel Steering

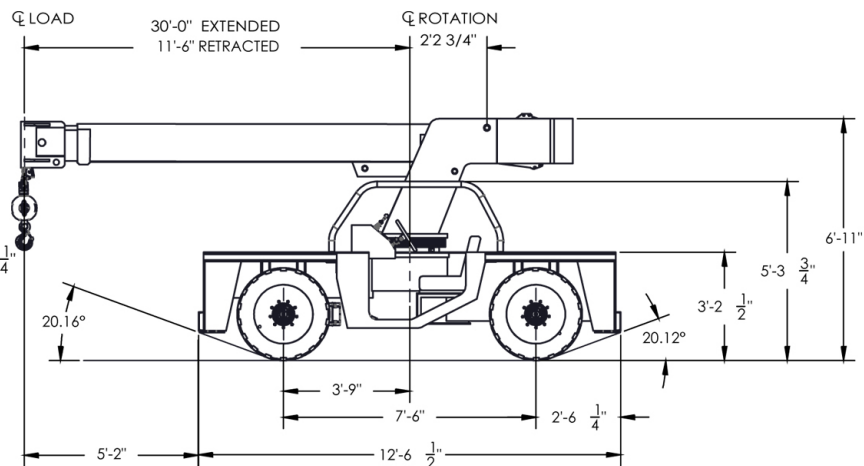
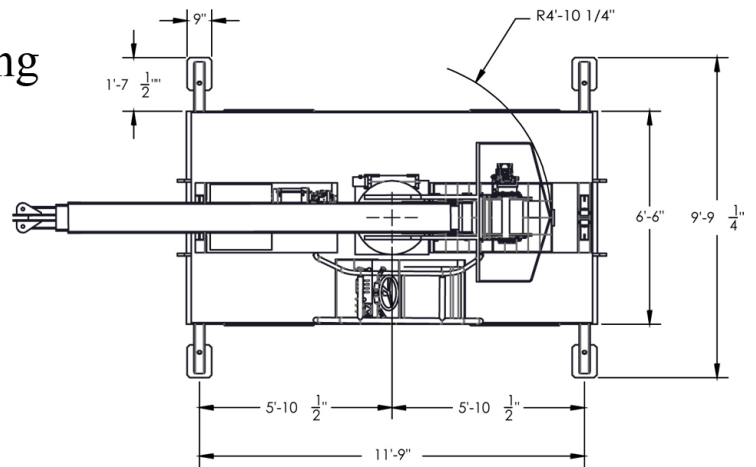



Hybrid Charging Engine on a pull-out engine tray for easy maintenance.

Display panel Information Center with integrated *Rated Load Indicator*.

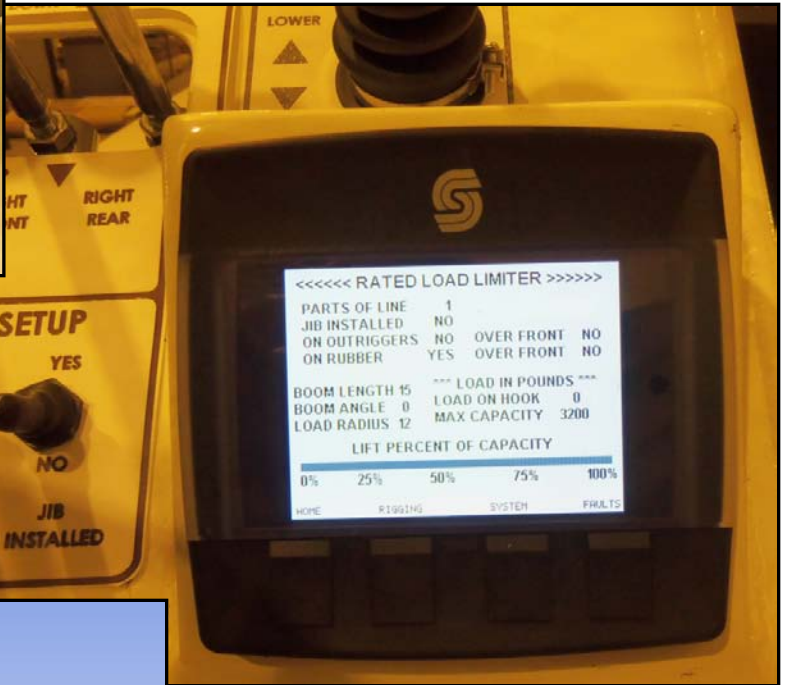

True "Torque Box" Chassis for industry-first stiffness and strength

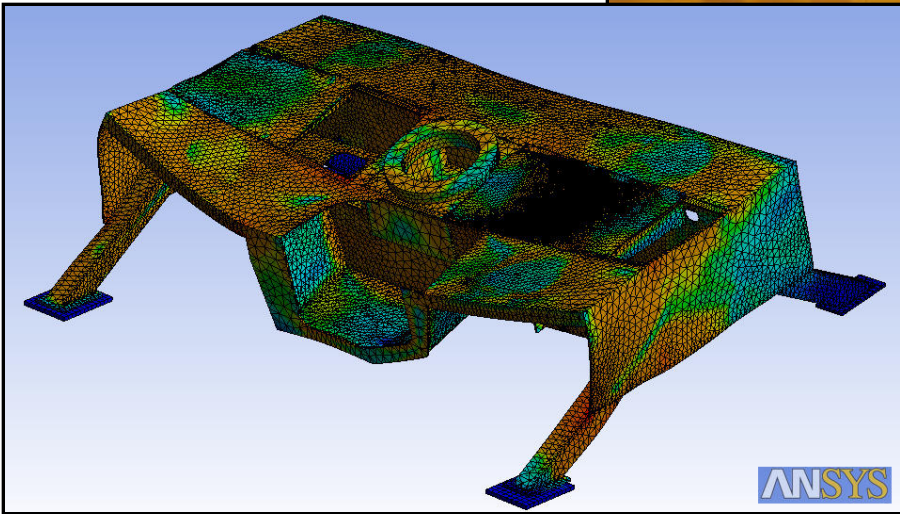

Battery watering cart with quick-connected makes filling fast and easy.



IC-18 OPTIONS

- Hybrid Charging Engine
- Propane, Gas, CNG, Diesel,
- 10' Boom Extension
- Radio Remote Control
- Non-Marking Tires
- Clean Room Package
- Omni-Directional Steering
- EE – Hazardous Location
- EX – Hazardous Location
- 46KV Insulated Jib
- Boom Tip Options
 - Powered Articulating Jib
 - Powered Rotator
 - Pallet Forks
 - Grabbers / Manipulators

CAPACITIES APPLY TO OPERATION ON FIRM LEVEL SURFACE

	LOAD	MAIN BOOM OR EXTENSION CAPACITIES IN POUNDS			
	RADIUS	360 ROTATION		OVER FRONT	
	FEET	ON RUBBER	ON OUTRIGGERS	ON RUBBER	ON OUTRIGGERS
MAIN BOOM	5	10000	17000	12000	18000
	6	8000	14000	10500	14000
	8	6000	10000	8700	10000
	10	5000	7700	6600	7700
	12	3800	6100	4800	6100
	14	2700	5200	3650	5200
	16	2100	4400	2900	4400
	18	1700	3900	2350	3900
	20	1400	3400	1900	3400
	22	1200	3050	1700	3050
	24	1100	2750	1450	2800
	26	950	2450	1350	2550
	28	850	2200	1300	2350
10' BOOM EXT.	30	700	1950	1200	2150
	32	450	1750	900	1950
	34	350	1600	800	1800
	36	350	1450	700	1650
	38	200	1300	600	1500
	40	150	1150	500	1400

10-FOOT BOOM EXTENSION

10-FOOT BOOM EXTENSION				
MAIN BOOM ANGLE				
0°	30°	45°	60°	70°
2250	2600	3200	5000	7000

CAUTION: BOOM EXTENSION LOADS MUST NOT EXCEED MAIN BOOM CAPACITY. DO NOT PICK & CARRY WITH LOADS ON BOOM EXTENSION.

CAPACITIES ON OUTRIGGERS ARE 85% OF TIPPING LOADS. CAPACITIES ON RUBBER ARE 75% OF TIPPING LOADS. CAPACITIES BELOW BOLD LINE ARE LIMITED BY TIPPING. OTHER CAPACITIES ARE LIMITED BY STRUCTURAL OR HYDRAULIC CAPABILITY.

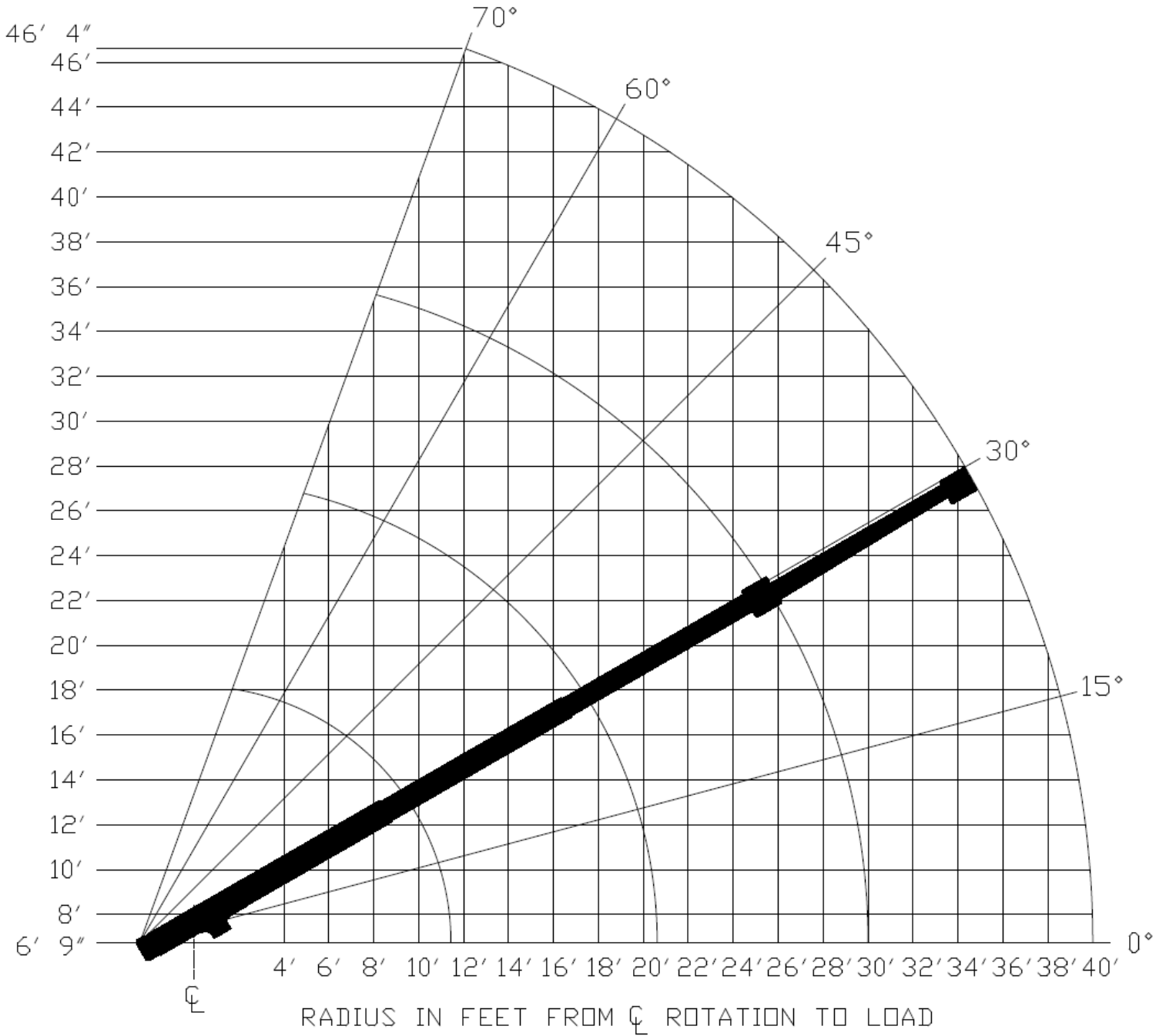

SPECIFICATIONS SUBJECT TO CHANGE- CONSULT FACTORY BEFORE PURCHASING

BAILEY CRANES
 8111 W BRADLEY ROAD
 MILWAUKEE, WI 53223
 414-446-8412
WWW.BAILEYCRANES.COM
SALES@BAILEYCRANES.COM

REV: NOVEMBER, 2013